

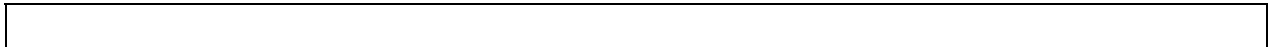

EGG WEIGH SYSTEM

INSTRUCTION MANUAL



National Poultry Equipment Company
3290 Lancer Avenue
Osage, Iowa 50461
TEL: (641) 732-1460
FAX: (641) 732-1470
email: poultry@osage.net
MANUAL REVISION: 2.1
MAN0213 May 2003

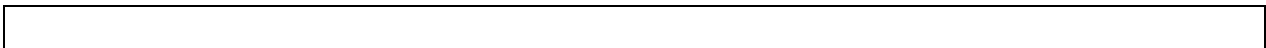

Made in USA



Table of Contents

Table of Contents	1
Introduction	3
Quick Start User's Guide	4
Fig. 1: Egg Weigh System Front Panel Layout.....	4
Power Up:	4
Basic Grading Operation:	4
Controls and Display Operation:	5
ZERO:	6
GRADE COUNT:.....	6
PRINT:	6
Flock Setup:	6
Setup Guide	7
Installation:	7
Fig. 2: Kicker and Weigh Module Location	7
Electrical Connections:.....	7
Load Cell and Power Connections:	7
Fig. 3: Indicator wiring connections	8
Serial Connections:	8
Fig. 4: Egg Weigh Module	9
Detailed Parameter Setup	10
Entering and Exiting the Calibration Setup Menu:.....	10
Fig. 5: Quick Access Panel	10
Stepping through the menu parameters:	10
Changing a Parameter:	11
Quick Review of Setup Parameters:.....	11
Calibration Menu	13
Digital Filter Setup Menu	13
Automatic Zero Tracking Setup Menu	14
Motion Aperture Setup Menu	14
Start Up Zero Setup Menu	14
Printer Data Output Setup Menu	14
Output Formats	15
Baud Rate Setup Menu	15
Start Up GRADE COUNT Selection Menu	15
Kicker One Location Menu	15
Table Size Setup Menu	16
Kicker and Sensor Test Mode	16
Raw Counts Display Mode	16
Chain Speed.....	16
Data Communications	17
Introduction to data communications:.....	17
Printer Modes:	18
Transmit on demand "Eod":.....	18
Continuous print "CP":.....	18
Data output format:.....	18

Fig 6. Sample "gct" Format printer output.....	18
GRADE COUNT Format "gct":.....	18
Fig. 7 Format "wgt" standard form.....	19
Weight Data Format "wgt":.....	19
Fig. 8 Format "gwt" form.....	19
GRADE COUNT and Weight Format "gwt":.....	19
Specifications and Interconnect Data.....	20
Table 1: Scale Specifications.....	20
Fig. 9: Indicator Load Cell connection.....	20
Table 2: Indicator TB1 Load Cell Connections.....	20
Fig. 10: RS232 serial cable wiring diagram.....	21
Table 3: Indicator P3 Wiring Connections.....	21
Fig. 11: Indicator Power Connections.....	21
Table 4: Indicator J4 Power Connections.....	21
Fig. 12: Indicator I/O Connections.....	22
Table 5: Indicator J2 I/O Connections.....	22
Table 6: Relay Box TB3 I/O Connections.....	23
Table 7: Relay Box TB4 Sensor Connections.....	23
Table 8: Relay Box TB5 Kicker Connections.....	23
Table 9: Relay Box J2 Power Connections.....	23
Fig. 13: Egg Relay Box and Indicator.....	24
Fig. 14: Installation of EMI / RFI / ESD protection devices.....	25
Troubleshooting.....	26
General problem resolution:.....	26
Resetting the scale parameters:.....	28
Resetting the scale:.....	28
Scale Messages:.....	28
Error messages:.....	29
PARTS LIST.....	30
WEIGHT INDICATOR.....	30
RELAY BOX.....	31
WEIGH MODULE.....	31

Introduction

Introducing the National Poultry Equipment Model NPE4300 Egg Weigh System. This scale sorting system employs state of the art technology to provide you with an accurate weighing solution. The Model NPE4300 offers many features:

- Six programmable grade weight levels – Grade 1 through 5 and one Reject Grade
- Counters to track each grades' sorted totals
- Store grade counts for up to ten flocks simultaneously
- Configure one grade to be distributed equally among several kickers on grade table
- Configure grade kicker location on grading table
- Large six digit, 0.56" bright red LED display
- g, oz display units supported.
- Full duplex RS-232 printer port
- EEPROM nonvolatile data storage of all calibration and grade setup information.
- Microprocessor monitoring system to prevent scale failure under severe fault conditions.
- 115/230 VAC 50/60 Hz operation
- Test mode for kicker and sensor connections

Please be sure to read the entire manual to ensure you obtain all the benefits that the Model NPE4300 can provide. If any questions arise, please feel free to contact the NPE Technical Support Department at 1-641-732-1460.

Unpacking Your Scale

Before unpacking your Egg Weigh System, please read the instructions in this section. Your new system is a durable industrial product, but it is also a sensitive weighing instrument. Normal care should be taken when handling and using this product. Improper handling or abuse can damage the scale and result in costly repairs that will not be covered by the warranty. If you notice any shipping damage, notify the shipper immediately. Please observe the following precautions to insure years of trouble free service from your new scale.

- DO NOT drop the indicator or weighing module.
- DO NOT immerse the indicator or weighing module.
- DO NOT drop objects on the weighing fingers.
- DO NOT pick up the weigh module by the weighing fingers.
- Carefully remove the indicator and module from the shipping carton.

Quick Start User's Guide

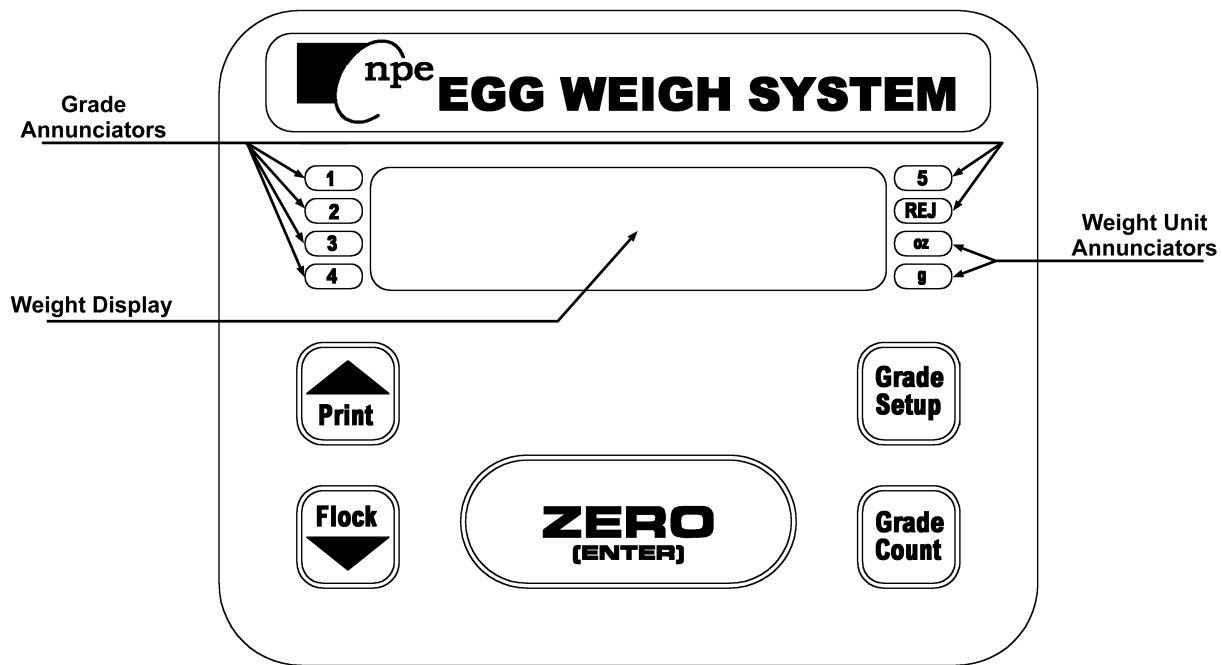

Fig. 1: Egg Weigh System Front Panel Layout

Power Up:

Connect the Model NPE4300 to a compatible power source with proper grounding. Do not remove the ground conductor from the scale plug. The Egg weigh System is designed to be left on indefinitely.

Basic Grading Operation:

- 1) Make sure weighing module fingers are clear of all debris.
- 2) Press ZERO to zero the scale. The weight display should now read zero.
- 3) Turn on conveyor, eggs are graded as they roll over weighing module fingers.
- 4) The sensor light will momentarily flash when each conveyor pin passes the sensor.
- 5) The indicator will add eggs to grade counter as the eggs are sorted by the corresponding kicker.

Entering new grade weight values:

- 1) Press the GRADE SETUP button to enter grade setup menu. Indicator will momentarily display “En Grd” then show the weight value of the grade 1.
- 2) Use the GRADE COUNT button to scroll through the five grades and reject value. The current grade is indicated by the annunciators to the left and right of the display. If menu reaches “LOC 1”, continue to press GRADE COUNT button until menu loops back to grade 1 value.
- 3) Once the desired grade number has been selected, use the up or down arrows to adjust the minimum egg weight for the individual grade.
- 4) Press the ZERO (ENTER) button to save new values and exit menu. The indicator will momentarily show “done”, and return to normal weighing mode.
- 5) To exit menu without saving new values, Press the GRADE SETUP button again. The indicator will show “Abort”, and return to normal weighing mode.

NOTE: When entering in the grade weight values, the lower the grade number (grade 1) the higher weight level (except for Reject) must be compared to the next subsequent grade number (grade 2). Only the Reject weight level must be set for a higher value than grade 1.

Assigning grade number to kicker locations:

- 1) Press the GRADE SETUP button to enter grade setup menu. The indicator will momentarily display “En Grd” then show the weight value of grade 1.
- 2) Press the GRADE COUNT button to scroll pass the 5 grades and reject value until menu reaches “LOC 1”. Continue to press the GRADE COUNT button for next location number in menu. If you pass your desired location press GRADE COUNT to scroll through the menu.
- 3) Once the desired kicker location number has been selected, use the up or down arrows to assign a grade number, reject or off setting to the kicker location. The kicker location on the grading table is indicated by the annunciators to the left and right of the display. The off setting is indicated when all annunciators to the left and right of the display are off.
- 4) Press the ZERO (ENTER) button to save new values and exit menu. The indicator will momentarily show “done”, and return to normal weighing mode.
- 5) To exit menu without saving new values, Press the GRADE SETUP button again. The indicator will show “Abort”, and return to normal weighing mode.

Controls and Display Operation:

The operational controls for the Model NPE4300 consist of the ZERO(ENTER), PRINT, FLOCK, GRADE SETUP, and GRADE COUNT buttons. A six digit LED display is used to provide weight indications, grade counts and operator messages describing system's operation. The current grade or reject count selected are indicated by four annunciators located to the left and the upper two annunciators located to the right of the main display. Scale units such as grams or ounces are displayed on annunciators located to the lower right of the display area (Fig. 1).

ZERO:

When the indicator is showing active weight, the ZERO button is used to zero the scale prior to making a reading. The ZERO button can function over the full range of the scale. To zero the scale, wait until the scale is stable and that the conveyor and fans are off, then press the ZERO button. The scale will zero immediately. The scale will not "zero" if the scale is in motion or not in active weighing mode. **Caution: The active weight should only be zeroed when there is no weight on the scale (i.e., do not push the zero button when eggs are passing across the weighing fingers).**

GRADE COUNT:

The GRADE COUNT button is used to view each individual's grade total (0 to 60,000) or active weight per flock. The 1, 2, 3, 4, 5, or REJ annunciators will indicate which grade value is being displayed. The g or oz annunciator will indicate when scale is displaying active weight and current units. Push the GRADE COUNT button to scroll through each corresponding grade or to view active weight. Press the ZERO button to clear the individual grade counter.

PRINT:

The PRINT button permits the operator to print the current weight or send a data stream to an external device like a PC or printer. The user must wait for the conveyor to stop before pressing the PRINT button as the indicator will not print while the scale is in motion. When stable, the current grade counts and/or weight will then be transmitted to the printer or external device.

Flock Setup:

The FLOCK button is used to select which of the 10 available flock grade totals to view, print, and count. This allows the user to track totals for up to 10 different flocks.

- 1) Press the FLOCK button to enter flock setup menu. The indicator will momentarily display "En FL", then "FL 1" which shows the currently selected flock number.
- 2) Press the GRADE COUNT button to scroll through the 10 available flock numbers.
- 3) Once the desired flock number has been selected, Press ZERO (ENTER) button to save new values and exit menu. The indicator will momentarily show "dOnE", and return to normal weighing mode.

Setup Guide

Installation:

The desired Weigh Module location should be level and free of any obstructions, which might interfere with the operation of the weighing fingers and conveyor. The Weigh Module should be mounted at a distance of 6.5" from the start of the first kicker location to the weighing fingers (Fig. 2). If because of clearance problems, the weigh module cannot be mounted at 6.5" distance. Module can be mounted at 4.5" distance, but calibration parameter kicker 1 location "Loc" must be set for "3", see Kicker One Location Menu on page 15 for more details.

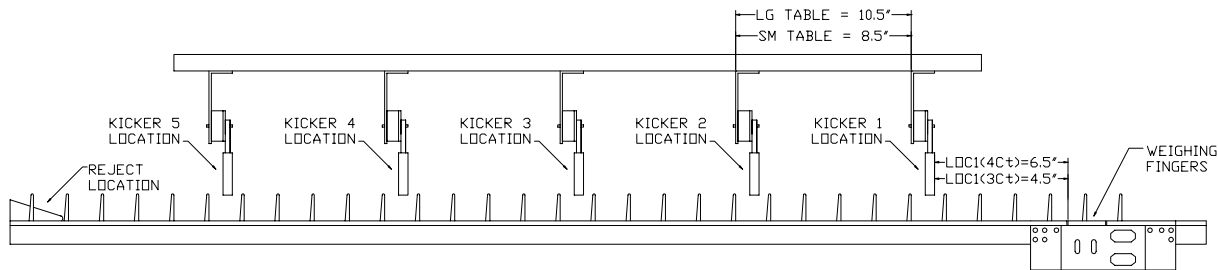

Fig. 2: Kicker and Weigh Module Location

Electrical Connections:

When installing your Egg Weigh System, make sure that an AC power outlet is close to the scale and easily accessible.

Prior to connecting your Model NPE4300 to power, check the serial number tag on the back of indicator for the correct operating voltage. Verify that your AC power matches the rated voltage on the indicator. The Model NPE4300 does not require powering down, and can be left on for long periods of time.

Be sure the AC power is not excessively noisy - this can occur if large inductive loads, such as solenoids or motors, are on the same power line. The Model NPE4300 has a filtered power supply to reduce the effects of normal line noise, but they cannot limit severe fluctuations. If problems occur, noise-producing devices may have to be installed to minimize their effect.

Load Cell and Power Connections:

Load cell connections are made through a terminal block located at the right of the main PC. Board (Fig. 3). The indicator power cord connects to a connector adjacent to the transformer. These connections are accessible by removing the rear cover of indicator.

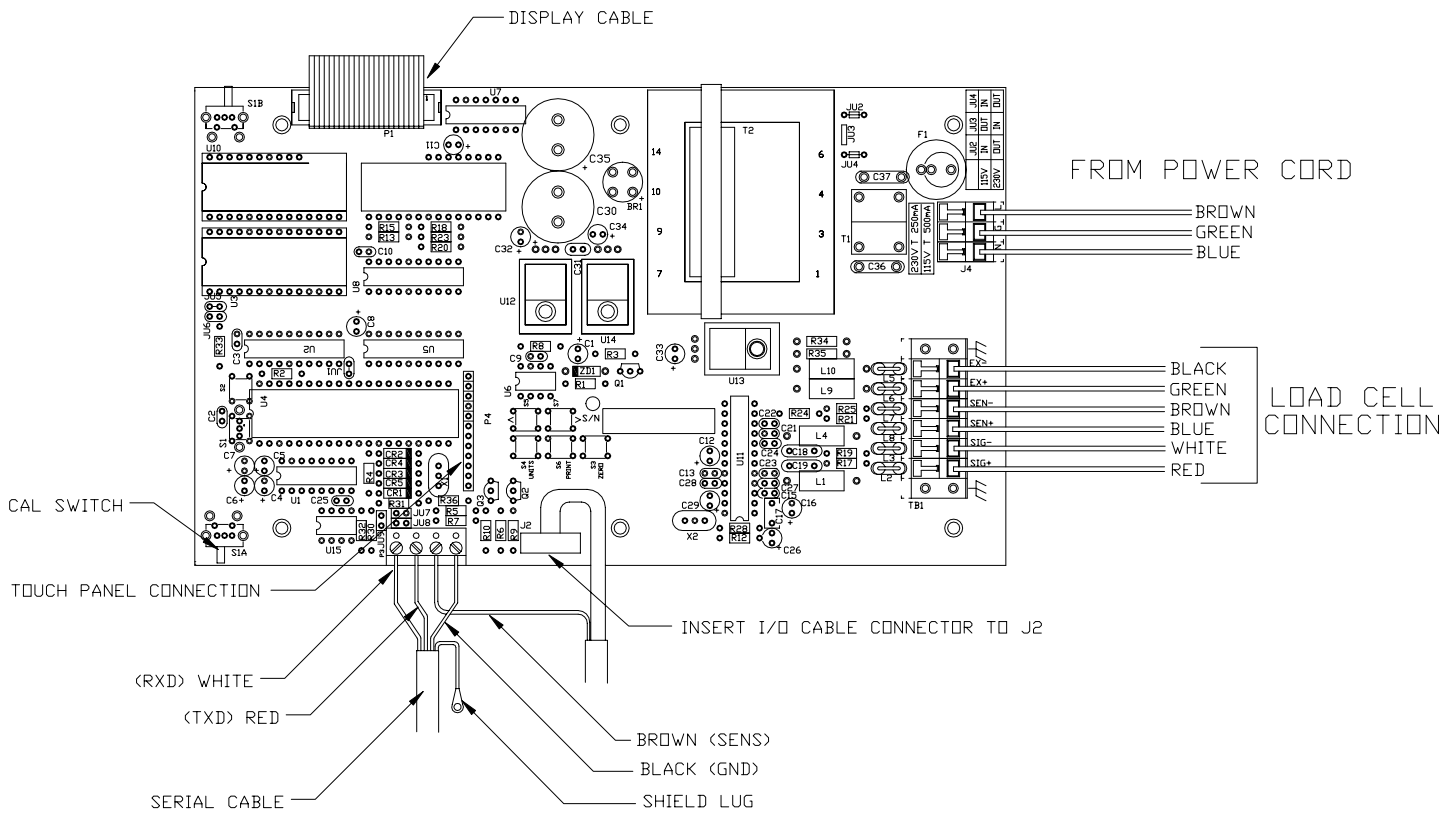

Fig. 3: Indicator wiring connections

The Calibration (S1) push buttons is located behind the Calibration Access Cover. This cover is located on the bottom side of indicator.

Serial Connections:

Every system has an external serial port to allow connection to a PC or printer with the optional NPE cable. See Parts List at the end of this manual for cable ordering information.

Calibration:

- 1) Press and release Calibration button to enter CAL menu, "SEALIC" will momentarily be displayed then "CAL 0" appears on the display.
- 2) Remove any unnecessary weight from the scale platter, clear away any debris from the weighing fingers and turn off all motors and fans, wait for about 10 seconds. Press **ZERO** and wait about 15 seconds. The display will return with "CAL200" for 200 gram calibration. **NOTE:** If "r9 Err" appears on the display, the calibration zero is out of range. Press zero to clear error. Refer to the analog setup section for additional information.

- 3) Place the 200 gram weight on the platter and wait about 10 seconds. Press **ZERO**. After about 15 seconds, the display will display "donE". Scale exits out of CAL menu. **NOTE:** If "SPAn E" appears on the display, the calibration span is out of range. Press zero to clear error. Refer to the analog setup section for additional information.

Analog test:

- 1) Momentarily press the Calibration button to enter CAL menu. Press and release **GRADE COUNT** until in the raw counts mode.
- 2) Remove all weight (eggs or debris) from the weigh module fingers.
- 3) Record the zero weight "no load" counts.
- 4) Place 200 gram weight on the platform and record the 200 gram counts. Subtract the "No Load" counts from the "200 grams Load" counts to calculate span. Refer to Table 1 and verify that the span falls within the limits specified for the amount of dead load present. If the readings, are outside of the limits specified, the load cell may be damaged or the load cell connections to the indicator motherboard may be faulty.

Weight on Fingers	Raw Counts
zero (No Load)	2.0000 to 4.5000 counts
200 grams	3.5000 to 5.5000 counts
Span range	1.2000 to 1.5000 counts

Table 1. Minimum span requirements

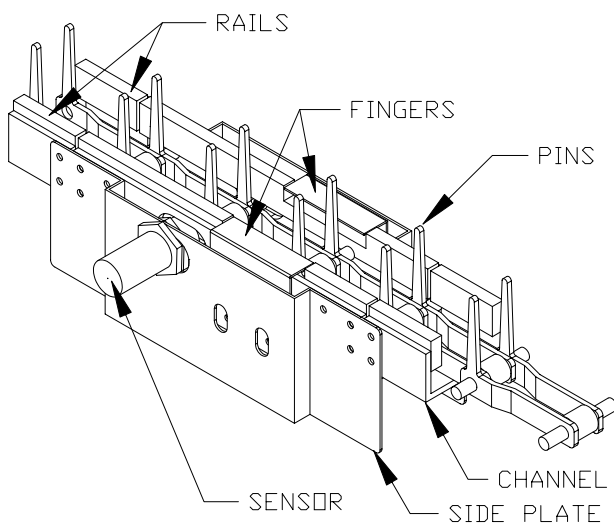

Fig. 4: Egg Weigh Module

Detailed Parameter Setup

The Model NPE4300 has 12 setup and calibration parameters, which can be accessed through the scale's Calibration Setup Menu.

Entering and Exiting the Calibration Setup Menu:

To enter the Calibration Setup Menu. Remove the two screws mounting the access cover located on bottom of indicator. Once opened, momentarily press the Calibration button (S1), location on main PC board (see Fig. 5) to enter Calibration menu. The indicator will momentarily display “~~STABLE~~” and then the first menu parameter, “CAL 0”.

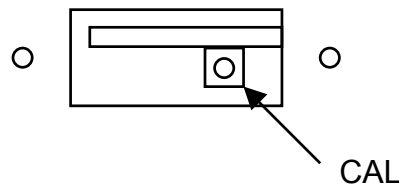

Fig. 5: Quick Access Panel

To exit the Calibration Setup Menu, simply press and release the CAL button to exit Calibration menu. The indicator will return to the normal weighing mode. All parameter selections, will be saved, including any just changed.

NOTE: No setup information is saved until the scale returns to the RUN mode. In the event of a power failure while in the Calibration Setup Menu, any changes that have been made will be lost.

After all setup changes are finished, and the indicator is in the normal weighing mode, re-install the access cover. Make sure the access cover and all the screws are re-installed in their original locations. Do not tighten screws to the point where the stainless steel access cover deforms – this will prevent proper sealing.

Stepping through the menu parameters:

Once the Calibration Setup Menu has been entered, you may step through the menu by pressing and releasing GRADE COUNT. A different display prompt will appear for each parameter in the menu.

The parameter list on the following pages corresponds to the parameters available in the Calibration Setup Menu.

Some of the menu parameters, when changed affect settings of other parameters. The scale will limit these parameters or automatically set the parameters to meet the new limits.

Changing a Parameter:

After finding the desired menu item, the parameters for that item may be changed. Press and release **ZERO** to step through the parameter list for that item. The list of choices will repeat if you keep pressing and releasing **ZERO**. When you have found the desired setting, press GRADE COUNT to go to the next menu item.

Quick Review of Setup Parameters:

Setup parameters for the Model NPE4300 may be quickly reviewed without opening the scale. Remove power and press and hold the **ZERO** button while you apply power. Hold the button until the scale begins to scroll through the setup parameters. The button may be released anytime after the review has begun. After parameters are displayed, scale will then go to the normal weighing mode automatically.

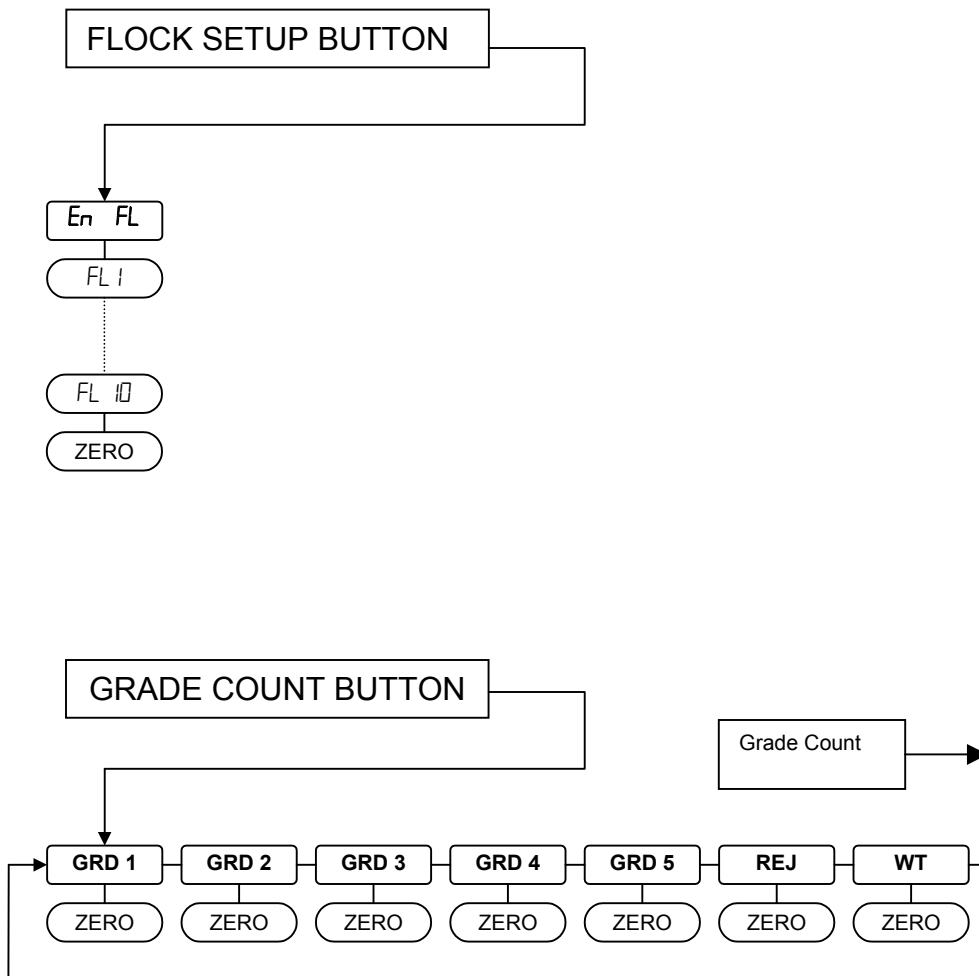

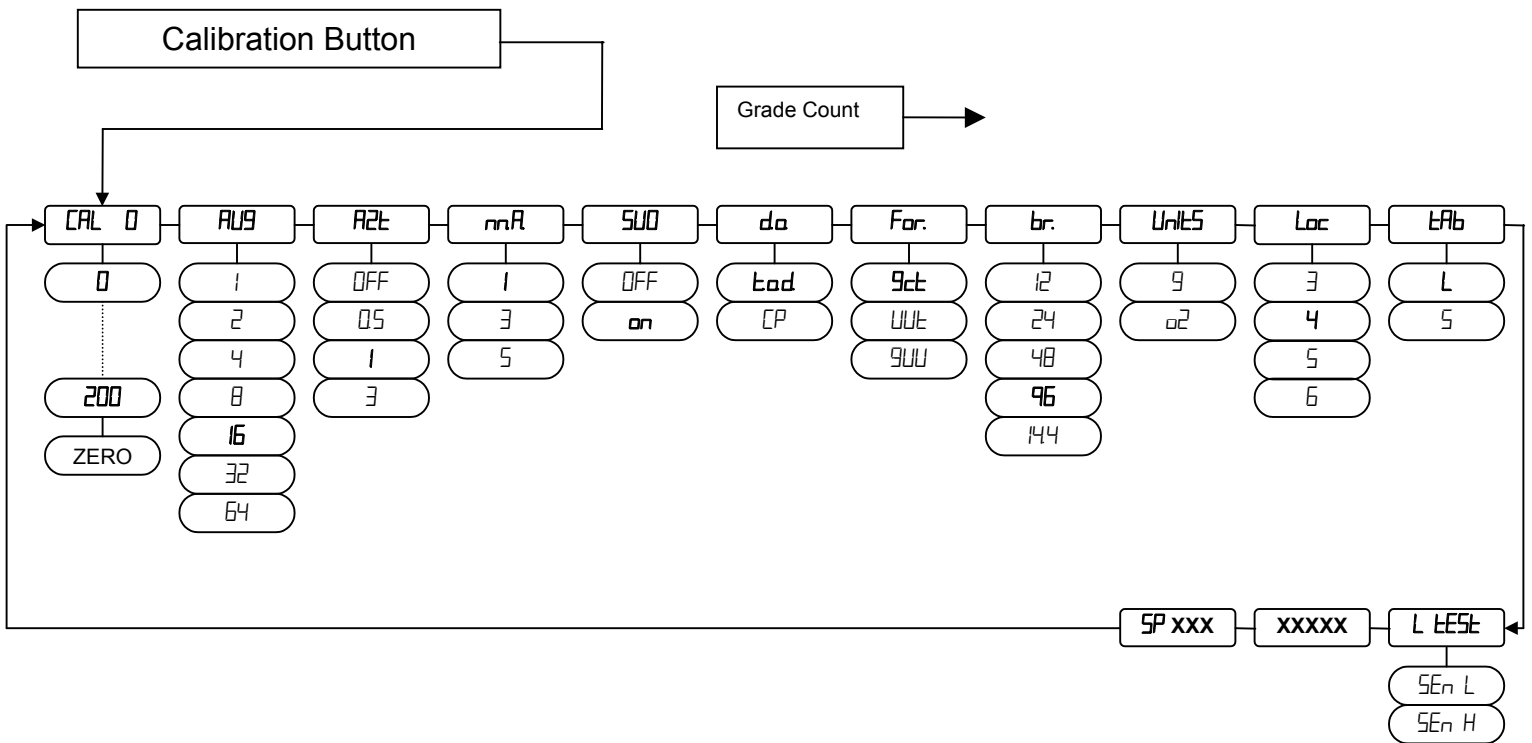
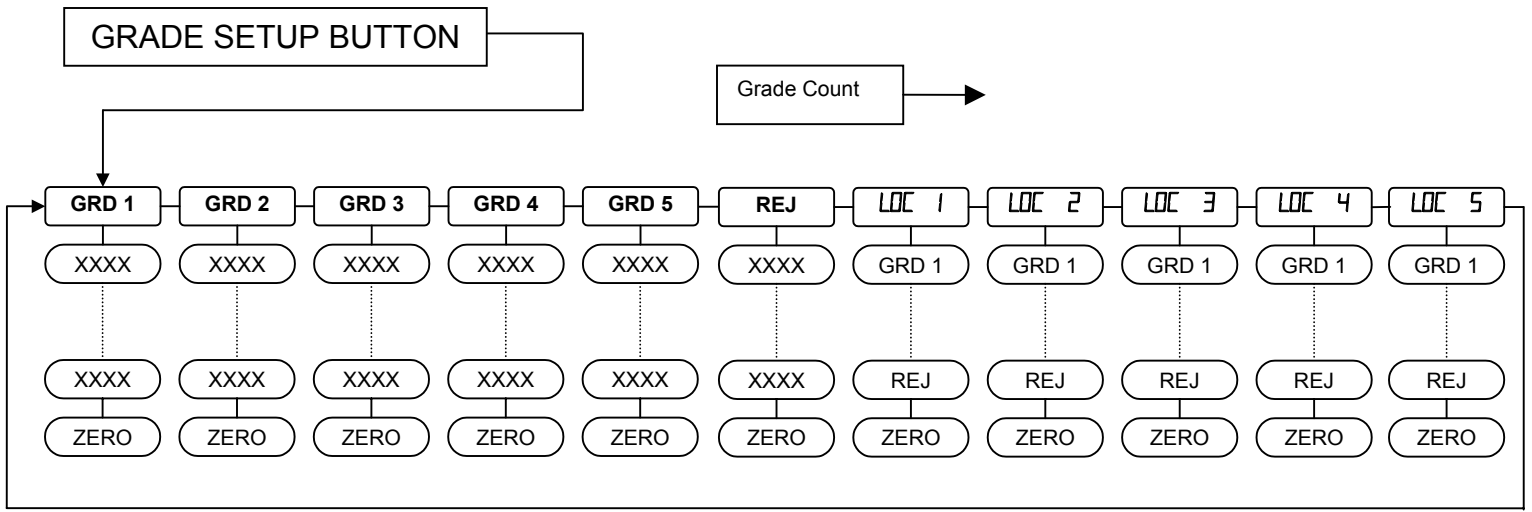

Calibration Menu

CAL 0	Zero Calibration Mode
	Press ZERO to perform calibration of the scale zero. Successful calibration is indicated by "done"

NOTE: The scale will automatically adjust the offset and gain to compensate for dead load and span. When making these adjustments, the scale may ask you to repeat zero calibration immediately after performing a zero calibration or after a span calibration. Successful calibration is indicated by "done"

CAL 200	200 gram Span Calibration Mode (Does not appear if CAL 0 is not activated.)
	Press ZERO to perform calibration of the scale at 200 gram load. Successful calibration is indicated by "done" then exiting out of Calibration menu.

Digital Filter Setup Menu

ALB	Averaging mode Determines the number of samples to average
1	Fixed averaging 1 readings are averaged. Display updates 44 times a second.
2	Fixed averaging 2 readings are averaged. Display updates 22 times a second.
4	Fixed averaging 4 readings are averaged. Display updates 11 times a second.
8	Fixed averaging 8 readings are averaged. Display updates 5 times a second.
16	Fixed averaging 16 readings are averaged. Display updates 3 times a second.
32	Fixed averaging 32 readings are averaged. Display updates 1½ times a second.
64	Fixed averaging 64 readings are averaged. Display updates 1 time every 1.4 seconds.

Automatic Zero Tracking Setup Menu

AZE	Automatic Zero Tracking Range Small weights within the specified number of grams are automatically zeroed.
OFF	Zero tracking is off. No automatic zeroing.
05	Zero tracking to within 1 gram.
1	Zero tracking to within 2 grams.
3	Zero tracking to within 6 grams.

Motion Aperture Setup Menu

MA	Motion aperture Determines how many consecutive grams readings must change before the scale is considered in motion.
1	0.2 grams change must be seen to enter motion.
3	0.6 grams change must be seen to enter motion.
5	1.0 grams change must be seen to enter motion.

Start Up Zero Setup Menu

SUZ	Start Up Zero Controls the start up zero status.
on	Zeros on the first stable reading on power up.
OFF	Loads the calibration zero for zero reference

Printer Data Output Setup Menu

DO	Data Output Mode Determines when serial data will be sent.
EOB	Transmit on demand. Print when the PRINT button is pressed.
CP	Continuous Print. Prints when sensor is activated and egg is on weighing fingers.

Output Formats

<i>For.</i>	Serial Data Output Format Defines the appearance of the serial data sent.
<i>gct</i>	GRADE COUNT Output, prints all grade and reject counts per selected flock number. (See the Data Communication section for details)
<i>UWt</i>	Egg weight Output, includes weighing units.
<i>gUU</i>	Prints both egg weight and grade count output.

Baud Rate Setup Menu

<i>br.</i>	Baud Rate Setup Determines baud rate for serial data.
<i>12</i>	1200 baud (bits per second)
<i>24</i>	2400 baud (bits per second)
<i>48</i>	4800 baud (bits per second)
<i>96</i>	9600 baud (bits per second)
<i>144</i>	14,400 baud (bits per second)

Start Up GRADE COUNT Selection Menu

<i>Units</i>	Start Up Units Select Mode Configures selection of start up weight units.
	Press ZERO to select between grams or ounces for the scale's startup units. The selected units will be displayed on the indicators to the right of the display.

Kicker One Location Menu

<i>Loc</i>	Location of First Kicker Selects number of pins or egg slots between the weighing fingers and the first kicker. (see Fig. 2)
<i>3</i>	3 pins between fingers & kicker, 4.5" distance
<i>4</i>	4 pins between fingers & kicker, 6.5" distance
<i>5</i>	5 pins between fingers & kicker, 8.5" distance
<i>6</i>	6 pins between fingers & kicker, 10.5" distance

Table Size Setup Menu

TABLE	Table Size Setup Selects the location distance between two kickers.
L	Large Table Size, 10.5" between Kickers
S	Small Table Size, 8.5" between Kickers

Kicker and Sensor Test Mode

L TEST	Kicker Location Test Test message will momentary be displayed. Kicker test starts at location 1 and pauses after kicker at location 5 has activated.
L TEST	Location test message will momentary be displayed.
SEN H	Sensor input at TB4 is High or Open, light on sensor is off.
SEN L	Sensor input at TB4 is Low or Closed, light on sensor is on.

Raw Counts Display Mode

Raw Counts	Displays the raw Analog to Digital converter data.
XXXXXX	Press GRADE COUNT to exit Raw Counts.

Chain Speed

Speed	Displays the speed of the conveyor chain in milliseconds.
SP XXXX	Press GRADE COUNT to exit Speed display.

Data Communications

Introduction to data communications:

In the Model NPE4300 data is sent to a printer or computer by using "asynchronous serial data communications." Data is broken up and sent one piece at a time to the printer or computer. In spite of this apparent simplicity, a basic understanding of serial data communications is needed when setting up the scale.

The scale transmits letters and numbers to a printer or computer by replacing the letter (or number) with an eight bit ASCII code. This code is then transmitted, one bit at a time, to a printer or a computer. A bit is the smallest unit of data and can have a value of "1" or "0." By combining eight bits into a byte, it is possible to get 256 unique bit patterns. These patterns are used to create the ASCII codes used by the scale to represent letters and numbers.

When setting up a serial communications system, there are several concerns which affect the configuration of that system. These are:

- transmission rate
- knowing when data starts and stops
- the ability of the receiving equipment to digest the data sent

The transmission rate determines how fast the data is sent from the scale to the printer (or computer) and is measured in Baud or bits per second. (For applications such as the Model NPE4300, Baud and bits per second are interchangeable.) The transmission rate controls how many bits can be sent in a given time. It is important that the sending and receiving speeds are set to the same Baud settings. Typical values are 1200, 2400, 4800 and 9600 baud.

The term "asynchronous serial data communications" implies that the sending unit has no way of telling the receiving unit when a data bit has been sent or when to expect the next bit. To correct this problem, both the sending and receiving speeds use the baud rate setting to determine how fast data should be sent. If the baud rates at the sending and receiving speeds differ, the receiving unit will expect data to arrive at a different time than when the transmitting unit sent it. When this happens, data will be lost. When the baud rates match, the receiving unit has no problem with the data arriving early or late. The only problem is knowing when the data transmission started.

The scale and the equipment connected to it resolve this dilemma by sending a "start bit" at the beginning of each data byte. This bit tells the printer or computer that a new data byte is on the way. When the start bit is received, the bit timer starts running and runs until it has received the correct number of bits.

The number of bits sent by the scale is controlled by the data bits, parity and stop bit configuration. The scale is factory set for eight bits, no parity and one stop bit. This means that the eight bits following the start bit will be data, followed by a stop bit. The stop bit signals the end of the data and permits the bit timer a chance to reset itself before the next data byte is sent. No parity bits are sent.

Printer Modes:

The Model NPE4300 offers two different print control modes. These modes dictate when printer data is sent.

Transmit on demand “⏏”:

In this mode, scale data is transmitted whenever the print button is pressed, the PRINT button is pressed, or a print request is received from the serial port. The scale must be stable and the conveyor is off before the data is printed.

Continuous print “⏏”:

In continuous print, data is transmitted each time a egg passes over the weighing fingers.

Data output format:

In order for the serial data sent from the scale to be useful, the data must be organized so that it is easy to read. There are three different types of data strings that can be transmitted from the indicator, the following will explain each of the output formats.

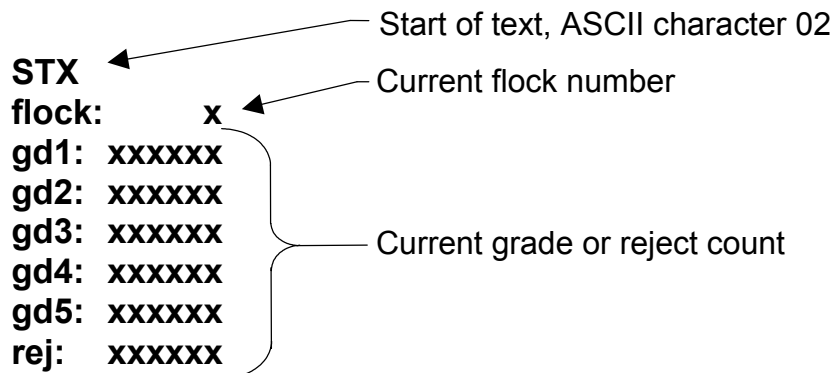

NOTE: Each line is terminated with a line feed & carriage return.

Fig 6. Sample gct Format printer output.

GRADE COUNT Format “gct”:

The grade count format allows the scale to send a data string that contains the selected flock number, and the current grades / reject counter values. Refer to Fig. 6 for details.

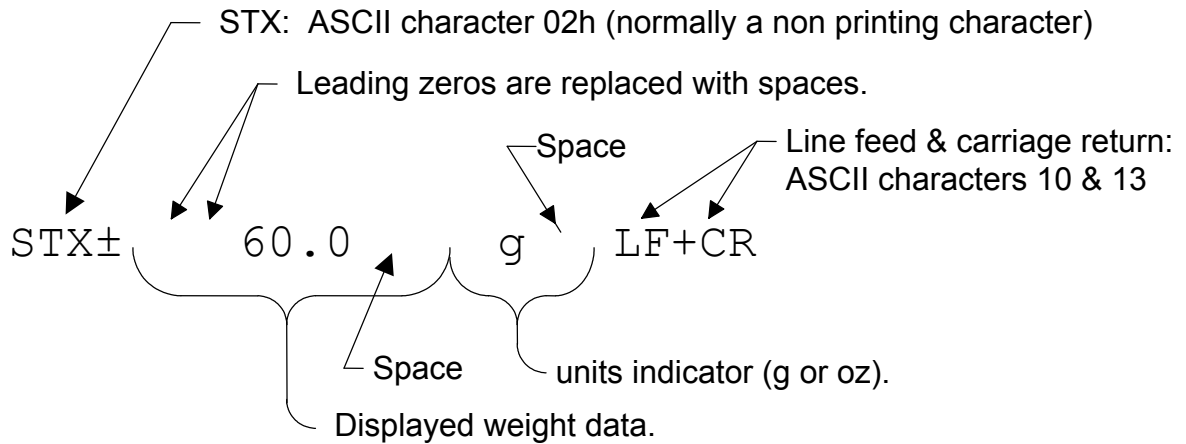
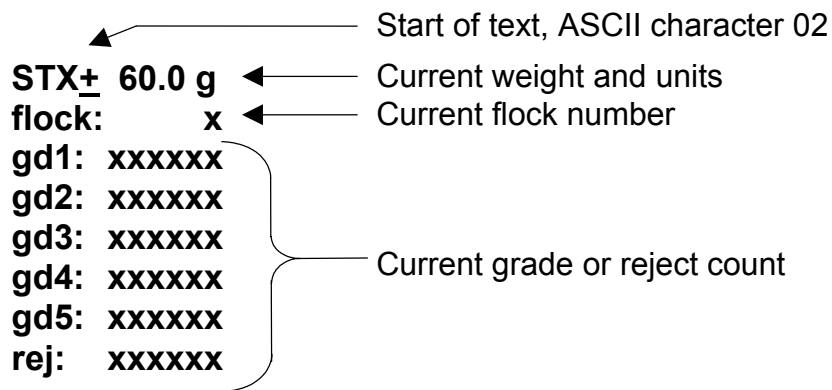

Fig. 7 Format "LLE" standard form.

Weight Data Format "LLE":

The egg weight data format sent by the scale is illustrated in Fig. 7. Each line of data begins with an STX character (start of text) followed by a polarity sign, which indicates the reading polarity. Next, the weight data is sent. Six digits are used with a decimal point inserted in the correct position. After the weight data is sent, a space followed by the Units are added to the string. The string is then finished by adding a line feed and a carriage return.



(NOTE: Each line is terminated with a line feed & carriage return.)

Fig. 8 Format "GLL" form.

GRADE COUNT and Weight Format "GLL":

In the grade count and weight format, the current weight is first printed using the "LLE" format, followed by the grade count format "GLL". Refer to Fig. 8 for details.

Specifications and Interconnect Data

Model NPE4300	
Resolution:	+0.2 grams
Accuracy:	+0.5 grams
Load Cell Capacity:	3 kg
Power Supply:	115/230 VAC 50/60 Hz
Display:	6 digit LED. 0.56" high
Displayed Units:	g and oz
Capacities:	200 grams
Printer Interface:	Bi-directional RS-232
Calibration	Unit may be calibrated with 200 gram test weight.
Controls:	ZERO, PRINT, FLOCK, GRADE SETUP and GRADE COUNT buttons.
Construction:	Rugged stainless steel NEMA 4/4x construction.
Options:	Serial communication cable with a female DB9 connector.

Table 1: Scale Specifications

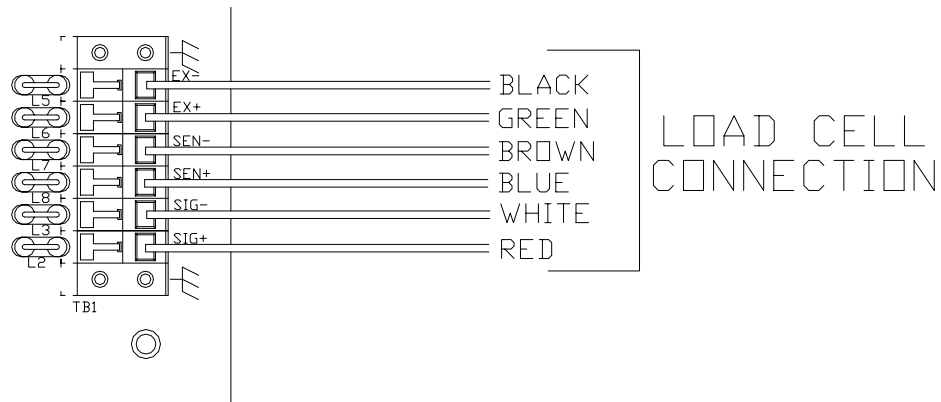

Fig. 9: Indicator Load Cell connection

TB1	TITLE	WIRE COLOR
1	GND	NONE
2	SIG+	RED
3	SIG-	WHITE
4	SEN+	BLUE
5	SEN-	BROWN
6	EX+	GREEN
7	EX-	BLACK
8	GND	NONE

Table 2: Indicator TB1 Load Cell Connections

NOTE: When connecting the load cell, be sure to install the ESD and EMI protection inductor. Refer to Fig. 14 for details.

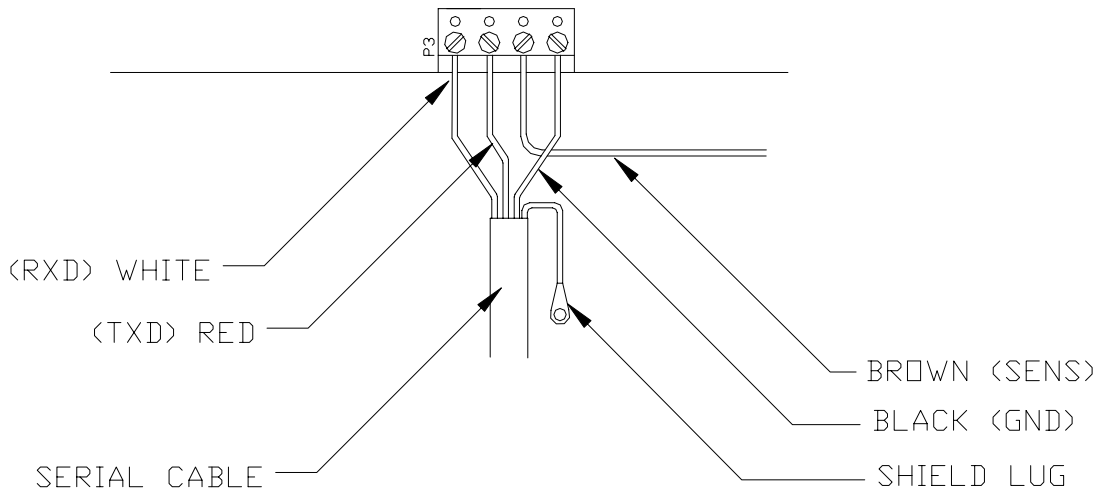

Fig. 10: RS232 serial cable wiring diagram

PIN	TITLE	WIRE COLOR
1	RTX	WHITE
2	TXD	RED
3	SEN	BROWN
4	GND	BLACK

Table 3: Indicator P3 Wiring Connections

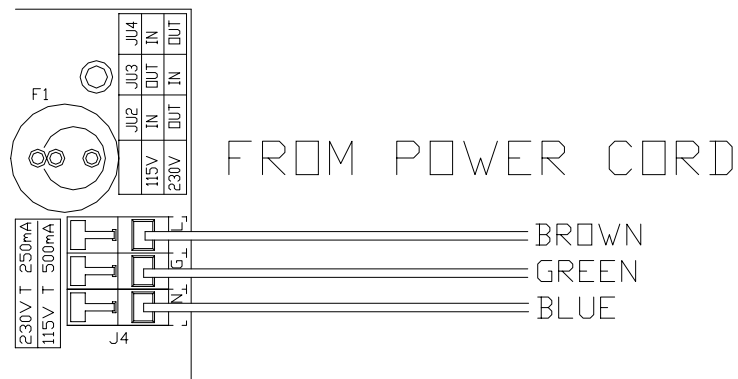

Fig. 11: Indicator Power Connections

J4	TITLE	COLOR
N	Neutral	BLUE
G	Ground	GREEN
L	Hot	BROWN

Table 4: Indicator J4 Power Connections

NOTE: When connecting the Indicator power be sure to install the ESD and EMI protection inductor. Refer to Fig. 14 for details.

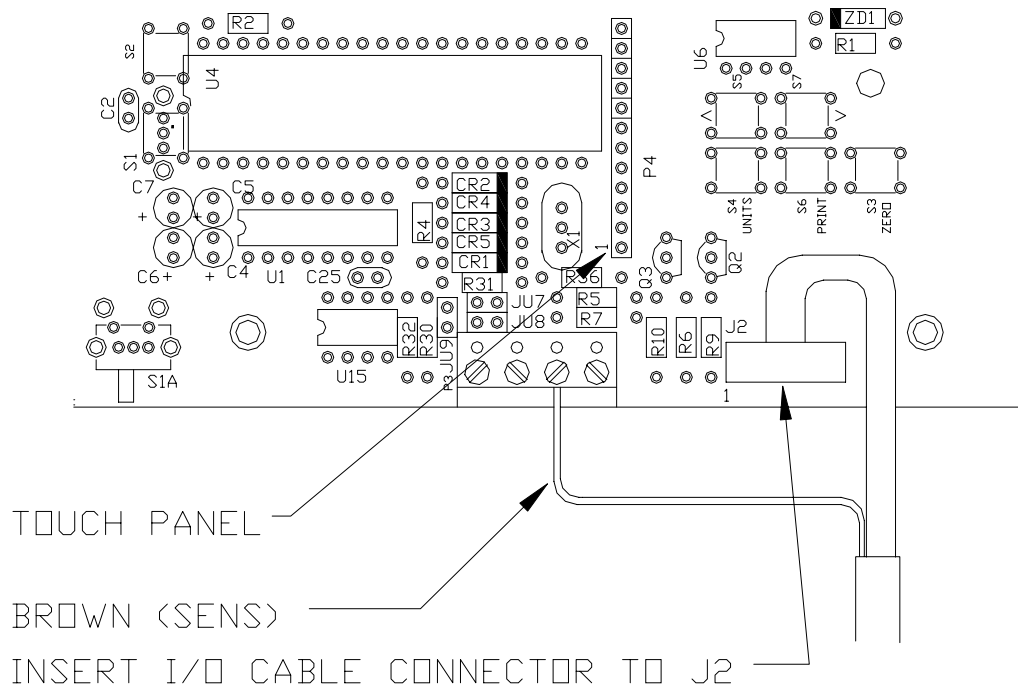

Fig. 12: Indicator I/O Connections

J2	TITLE	COLOR
1	KICKER 2	RED
2	KICKER 3	WHITE
3	KICKER 4	GREEN
4	KICKER 1	ORANGE
5	KICKER 5	BLUE
6	GND	BLACK

Table 5: Indicator J2 I/O Connections

TB3	PIN	COLOR
1	1	ORANGE
2	2	RED
3	3	WHITE
4	4	GREEN
5	5	BLUE
SEN	6	BROWN
GND	7	BLACK
GND	8	NONE

Table 6: Relay Box TB3 I/O Connections

TB4	PIN	COLOR
1	SEN	BLACK
2	GND	BLUE
3	POS	BROWN

Table 7: Relay Box TB4 Sensor Connections

TB5	PIN	COLOR
1	1	RED
GND	2	GRAY
2	3	YELLOW
GND	4	BROWN
3	5	BLUE
GND	6	WHITE
4	7	GREEN
GND	8	TAN
5	9	PURPLE
GND	10	PINK

Table 8: Relay Box TB5 Kicker Connections

J2	PIN	COLOR
1	L	BROWN
2	G	GREEN
3	N	BLUE

Table 9: Relay Box J2 Power Connections

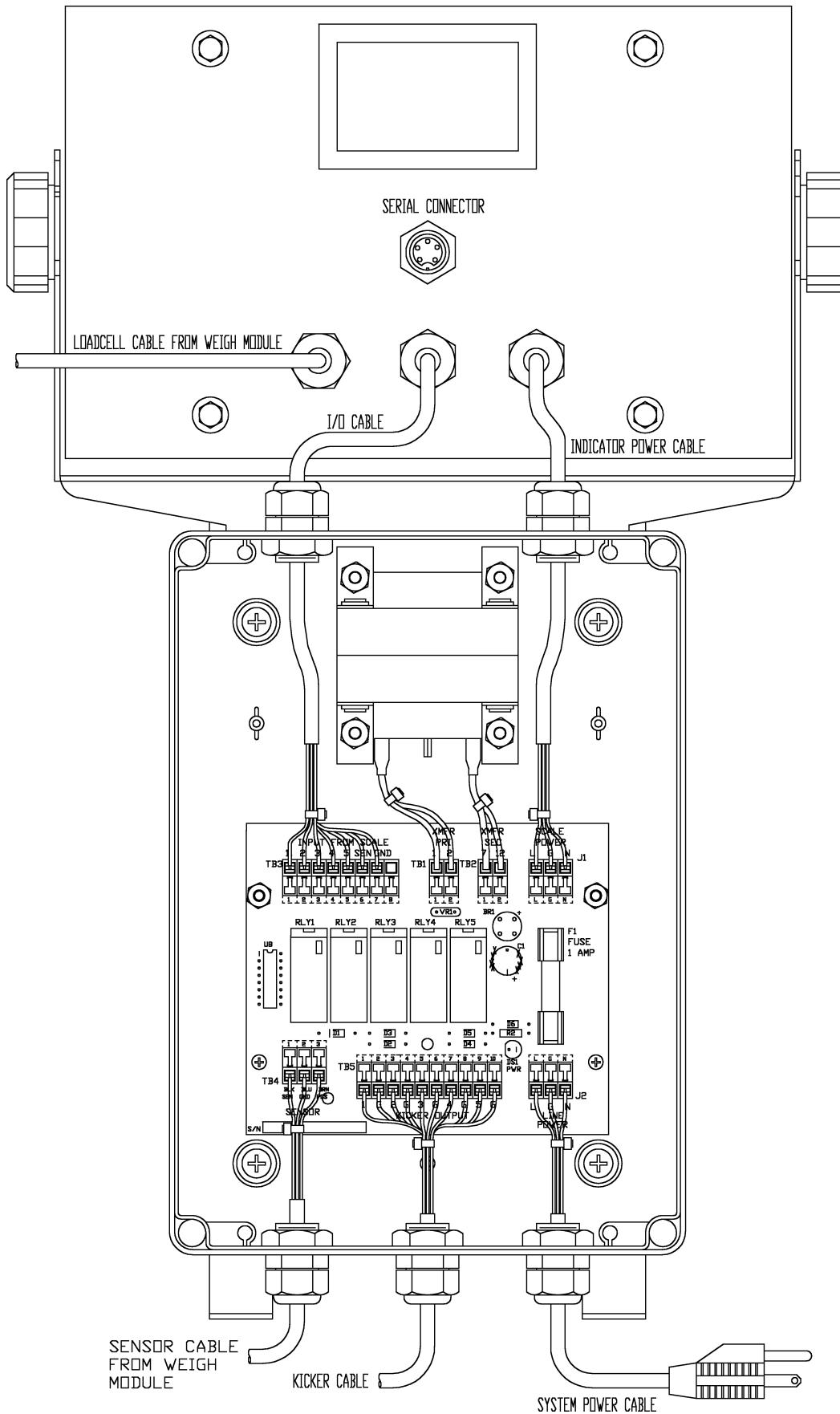

Fig. 13: Egg Relay Box and Indicator

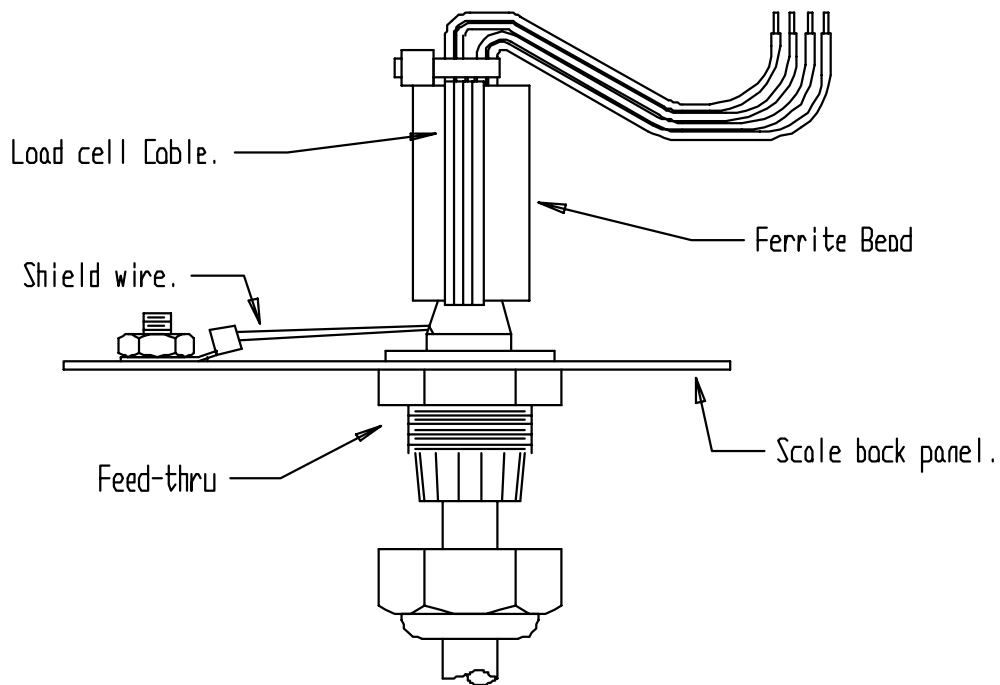

Fig. 14: Installation of EMI / RFI / ESD protection devices.

Instructions:

1. Strip the outer jacket of the load cell the distance between the back panel and the load cell terminal block, plus 6".
2. Feed all conductors of the load cell cable through the **feed thru**.
3. Cover the shield wire with shrink tubing (1/8")
4. Solder the ring terminal (**HDW0030**) to the shield wire.
5. Cover the solder connection with shrink tubing (1/4")
6. Connect the shield wire to the nearest stud on the case. The length of this must be 3" or less.
7. Feed the rest of the wires through the ferrite bead (**IND0004**). Then wrap the wires back through (end to end) so that there is a complete turn through the ferrite bead.
8. Pull tight and install cable tie (**HDW0013**) at the top of the assembly.
9. Cover the ferrite bead with shrink tubing (1/2") or electrical tape.
10. Connect the conductors to the load cell terminal block on the main board.

Troubleshooting

General problem resolution:

Problem:	What to Do or Check:
Kickers are not activating but, Indicator is counting eggs.	<ol style="list-style-type: none"> 1. Look inside Relay Box and make sure power led is lit, if not check fuse next to led. 2. Run Kicker and Sensor Test Mode "L TEST" to verify system's wiring connections. 3. All or some location settings in the GRADE SETUP menu are turned off.
Kickers are not activating and Indicator is <u>not</u> counting eggs.	<ol style="list-style-type: none"> 1. Make sure light in Sensor is flashing when conveyor is running. 2. Grade weight values are set to wrong levels. 3. Check Sensor position in weigh module. 4. All or some location settings in the GRADE SETUP menu are turned off. 5. Make sure that there is nothing interfering with the movement of the weighing fingers, loadcell or spider. 6. Run Kicker and Sensor Test Mode "L TEST" to verify system's wiring connections.
All Kickers are activating early or late.	<ol style="list-style-type: none"> 1. Verify the spacing between the first kicker location and weighing fingers, see Fig. 2. 2. Make sure parameter "LOC" "Location of first kicker is set for the proper spacing (4 = 8.5)". 3. Grade weight values are set to wrong levels. 4. Make sure scale is reading zero when the conveyor and fans are off. 5. Check Sensor position in weigh module.
Kickers at location 2-5 activating early or late. Kicker at location 1 works.	<ol style="list-style-type: none"> 1. Verify the spacing between the kicker locations are 8.5" or 10.5". 2. Make sure parameter "TAB" Table Size is set for the proper spacing, Large (10.5") or small (8.5"). 3. Grade weight values are set to wrong levels. 4. Make sure scale is reading zero when the conveyor and fans are off.
Weight reading will not repeat or scale does not return to zero when weight is removed and conveyor is off.	<ol style="list-style-type: none"> 1. Verify that there is nothing interfering with the movement of the weighing fingers, loadcell or spider. 2. The Automatic Zero Threshold "AZL" parameter may be set too high. 3. Loadcell wiring connections with scale may be loose. 4. Check for air currents from last fan to see if it is effecting weighing fingers. 5. Check for a build up of water under weighing fingers.

<p>Heavier eggs are sorted to a lower grade weights.</p>	<ol style="list-style-type: none"> 1. Verify that there is nothing interfering with the movement of the weighing fingers, loadcell or spider. 2. Check Sensor position in weigh module. 3. Make sure scale is reading zero when the conveyor and fans are off. 4. Use test weight to verify scale's calibration. 5. Conveyor system has excessive vibration. 6. Check for air currents from last fan to see if it is effecting weighing fingers. 7. Check for a build up of water under weighing fingers.
<p>Scale will not come to zero when the ZERO button is pressed.</p>	<ol style="list-style-type: none"> 1. Make sure that the scale is stable when ZERO is pressed. If excessive motion is a problem, then it may be necessary to turn off all motors and fans. 2. There may be a problem with the touch-panel or main board.
<p>Weight readings don't seem to be correct.</p>	<ol style="list-style-type: none"> 1. Check the scale's accuracy with a test weight. Recalibrate if necessary. 2. The Automatic Zero Threshold "AZL" parameter may be set too high. 3. Check for air currents from last fan to see if it is effecting weighing fingers. 4. Use test weight to verify scale's calibration.
<p>Scale drifts off of zero.</p>	<ol style="list-style-type: none"> 1. Check for air currents from last fan to see if it is effecting weighing fingers. 2. Check for a build up of water under weighing fingers. 3. The Automatic Zero Threshold "AZL" parameter may be set too high. 4. Loadcell wiring connections with scale may be loose. 5. Verify that there is nothing interfering with the movement of the weighing fingers, loadcell or spider.

If you are still experiencing a problem with your scale, or if the problem you are having is not covered in the above list, please contact NPE.

Resetting the scale parameters:

- If at some point the Model NPE4300, user wishes to return the setup parameters to factory default, follow these steps.

WARNING: Defaulting the scale will require recalibration.

- Remove power.
- Press and hold CAL button while power is restored.
- The indicator will display "inE" and then "rEL Pb" until the CAL button is released. After the "rEL Pb" message is displayed the scale then performs its normal power up routine and enters the Calibration mode. At this time, all the parameters will have been reset to their factory default settings. See Setup Menus Explained section for details on setting up the individual scale parameters.
- Return to the normal weighing mode by momentarily pressing CAL button. The scale will save the revised parameters and will enter the normal weighing mode.

Resetting the scale:

In the event that a power problem has disabled the scale, remove power, wait 15 seconds and restore power. The scale should restart and function properly.

Scale Messages:

Message	Meaning
"Abort" Aborted Function.	The requested action has been canceled prior to completion.
"done" Function complete.	The scale has successfully completed the requested action.
"En Grd" Enter Grade value	The Indicator momentarily display message before entering GRADE SETUP menu.
"En FL" Enter Flock Number	The Indicator momentarily display message before entering Flock number selection menu.
"FL 1" Flock Number	Message shows which flock number is currently selected, appears after "En FL" is displayed.
"inE" initialize	The message appears only when resetting parameters settings in nonvolatile memory.
"LOC 1" Location 1	Message appears in GRADE SETUP menu, indicates Location or Kicker 1 setting.
"rev 1.0" Revision number	The right two digits indicates the software revision number, i.e. "rev 1.0".
"DSW 076" Software number	The right two digits indicates the software part number, i.e. "DSW0076".
"SAVED" Parameter value saved.	The scale has successfully store and verified parameter value in nonvolatile memory.
"LDG 0" Loading zero.	The scale is attempting to load power up zero. This message will remain until scale is stable.

Error messages:

Error Message	What to Do or Check:
" <i>oUr-Ld</i> " Scale overload	The scale is in overload. The load on the scale exceeds the capacity by more than 103%. Remove excess weight from scale.
" <i>uDr-Ld</i> " Scale underload	The scale is in underload. The load on the scale is less then the minimum scale capacity by more than - 20%. Recalibrate scale.
" <i>GrS-oL</i> " Gross overload	The scale is in gross overload. The load exceeds the scale ratings and might result in damage to the scale. Remove excess weight immediately. Ignore this message for the first 5 seconds after power up.
" <i>GrS-uL</i> " Gross underload	The scale is in gross underload. The load exceeds the minimum scale ratings and might result in damage to the scale. Loadcell connections might be wired in reverse. Ignore this message for the first five seconds after power up.
" <i>SU 0 E</i> " Startup zero error	The scale was not stable. The scale will zero once it becomes stable.
" <i>Er Ad</i> " A/D failure	The scale has detected a failure in A/D timing circuit. Have scale serviced by a qualified scale repair technician.
" <i>Err EP</i> " EEPROM error	The setup parameters loaded in nonvolatile memory have become corrupted. The scale requires reinitialization by a qualified scale technician.
" <i>Er CAL</i> " Calibration error	The calibration values loaded in nonvolatile memory have become corrupted. The scale requires recalibration by a qualified scale technician.
" <i>Er SAE</i> " Calibration error	The static memory (U10) in scale is missing or defective. Have scale serviced by a qualified scale repair technician.
" <i>Er rom</i> " Program ROM error	The program memory (U3) in the scale has become corrupted. Have scale serviced by a qualified scale repair technician.
" <i>no SAU</i> " EEPROM error	The setup parameters failed to save to nonvolatile memory. The scale requires reinitialization by a qualified scale technician.
" <i>rEL Pb</i> " Release button	The front panel push button pressed. If message does not clear after 10 seconds. Have scale serviced by a qualified scale repair technician.
" <i>SPAn E</i> " Calibration error	The calibration span is out of range. Press zero to clear error. Refer to the analog setup section for additional information.

PARTS LIST

WEIGHT INDICATOR

SUB0477	<u>Indicator PCB Assembly 115 VAC</u>
SUB0477D	<u>Indicator PCB Assembly 230/VAC</u>
DSW0076	<u>Program Memory IC</u> Software Chip
SWI0118	<u>Touch Panel – Graphics Layer</u> Requires touch panel adhesive SHP0099
SHP0099	<u>Touch Panel Adhesive – Graphics layer</u>
SWI0103-B	<u>Touch Panel Switch Assembly</u>
FUS0020	<u>Fuse, 1/4 Amp, Slo-Blo - Indicator</u> For 115VAC models
FUS0019	<u>Fuse, 1/8 Amp, Slo-Blo - Indicator</u> For 230VAC models
4300-018	<u>Calibration Port Cover Assembly</u> 2 10-32 screws with rubber washers; rubber gasket for panel
SUB0438	<u>Gasket & Screw Set , Rear Panel</u> 3 standard & 1 cross-drilled 10-32 screws with rubber washers; rubber gasket for rear panel
ENC0604-1	<u>Rear Panel - Indicator</u> Back cover for Indicator
SUB0478	<u>RS-232 Data Cable</u> With 9 pin female connector for connection to a PC
ENC0652	<u>Tower, 14” Column</u>
MSC0085	<u>Scale Veil</u> Protective plastic stitched cover for meter
SUB0210-1	<u>Knob, “U” Bracket Adjust</u> One Friction adjust knob with washer
MAN0213	<u>Instruction Manual</u>
CNT0019	<u>Liquid-Tite Feed Thru</u> For load cell, power cord, sensor and RS-232 inputs

RELAY BOX

PCA0249	<u>Relay PCB Assembly 115 VAC</u> Includes all 5 relays
PCA0249D	<u>Relay PCB Assembly 230/VAC</u> Includes all 5 relays
ENC0720	<u>Relay Enclosure</u>
SUB0473	<u>Kicker cable assembly</u> Cable fits small and large tables
4300-009	<u>Power Cord</u> Shielded, 8ft long, for relay box
XFR0033	<u>Transformer, Relay box</u>
RLY0029	<u>Relay for kicker</u> One per kicker output
FUS0001	<u>Fuse, 1 Amp – Relay Box</u> For 115/230VAC models
CNT0019	<u>Liquid-Tite Feed Thru</u> For load cell, power cord, kicker and option inputs

WEIGH MODULE

SUB0471	<u>Egg Weigh Module</u> Complete weighing module with sensor
MSC0109	<u>Sensor, Conveyor</u>
ENC0722	<u>Weighing Fingers</u> 2 per weighing module
ENC0726	<u>Duron Rails</u> 2 per weighing module
MSC0110	<u>Test Weight, 200 grams</u>